

# USING OF WASTE HEAT OF INTERNAL COMBUSTION ENGINES AND DRAFT OF EXHAUST GAS HEAT EXCHANGER.

Ing. Miloš Brezáni<sup>1</sup>, doc. Ing. Róbert Labuda, PhD.<sup>1</sup>, Ing. Peter Baran<sup>1</sup>

Faculty of Mechanical Engineering – Department of Transport and Handling Machines – University of Zilina, Slovak Republic  
milos.brezani@fstroj.uniza.sk

**Abstract:** Article discusses about the use of heat exchangers for stationary combustion engines and cogeneration units. The paper is dedicated to the problem of unused thermal energy in stationary engines. It analyses possibilities of accumulation of heat energy and its possible application in various fields. The paper deals with the classification of heat exchangers and with the subsequent description of design solutions of heat exchangers types used in given field. Resolves draft of exhaust gas heat exchanger according to the required parameters of internal combustion engine and subsequent simulation in the simulation program Comsol multiphysics to verify the correctness of the design and the construction solution of the exhaust gas heat exchanger for stationary combustion engines.

**Keywords:** HEAT EXCHANGERS, COGENERATION UNIT, WASTE HEAT, COMBUSTION ENGINES, DRAFT, SIMULATION

## 1. Introduction

Nowadays if we omit alternating economic crisis we can talk about ecological time. Political thinking towards just environmental but also economical, gives new insight into the lifestyle and comfort of man. A great impact just on these aspects has energetic. It is due to the increasing energy demands of human society, on which depends in no small measure the environmental burden and efficiency of energy use.

Possibility how to reduce energy consumption, is the way of savings. Reduction in fuel consumption can be utilized in a direction, which deals with the production of several types of energy, and possibly also of the products from the primary source at the same time. To this category can include cogeneration, trigeneration and polygeneration. Find a use for the heat is not as easy as in the case of electrical energy. But nevertheless is being offered several options, such as use of heat for hot water or direct water heating and its subsequent use for houses or large objects, depending on the performance of the cogeneration unit itself. Another option would be to use the absorption unit to transform heat to cold, making it possible to extend services to the production of cold water, for example for supply of air conditioners.

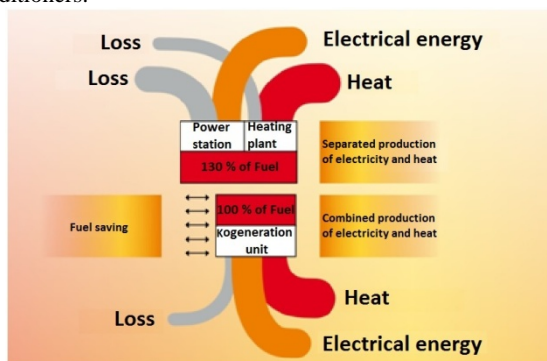
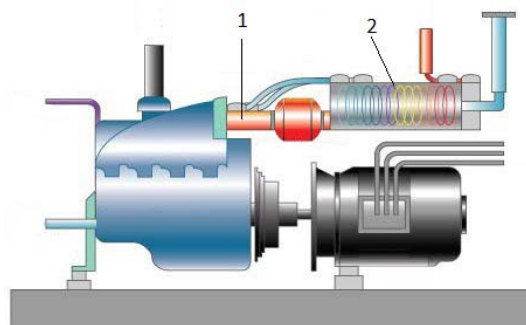

Fig. 1 Cogeneration principle

For all these systems the energy transformation is decisive the method how to submit it. For this intention in case of heat is used inseparable part of most of the systems which is called the thermal coupling node. Thereby may be various types of heat exchangers, coolers, condensers etc. The most common devices nowadays belong heat exchangers. In this case, for the generation of thermal energy from the exhaust gas and its subsequent use in other applications.

## 2. Use of heat exchangers in cogeneration units and stationary internal combustion engines.

For use of stationary internal combustion engine to generate electricity, or in other applications, arises a waste heat [1]. In most cases, this heat is not used in any way, but today's time more and more forcing producers and consumers to invest in technology that can leverage the potential of unused energy and contribute to cost saving. To this end has started to use exhaust gas heat exchangers. An exhaust heat exchanger is positioned on the exhaust pipe, removing heat flue gases, which could then be used for various applications.



1 - Exhaust gas pipe, 2- Exhaust gas heat exchanger

Fig. 2 Position of exhaust gas exchanger in stationary combustion engine

Exhaust gas temperature at the start of the exhaust pipe is in the range 500-700 °C. This means that the exhaust gases offer a great potential for utilization of waste heat. The exhaust gases in the most of cases heat up liquid, which can subsequently be used in several ways.

## 3. Heat exchanger

Device used for targeted transfer heat energy from the one heat medium to another one, according to the second law of thermodynamics, is called a heat exchanger [2]. These facilities include a large group and can be found in many sorts of systems without us realizing it. According to the purpose and primarily according to the action, which takes place in the heat exchanger can be divided into the condensers, evaporators, coolers, regenerative heat exchangers etc. Another division is quite normal according to the method of heat transfer, i.e. whether there is contact between the media etc.

Heat exchangers are divided into:

- Recuperative - media are separated by a solid impermeable wall and not coming into contact
- Regenerative - occurs periodically substituted flow heating and cooling media in the defined area.
- Contact - media come together for some time in contact without chemical reaction, and then are separated.
- Mixing - media are in a certain place mixed and continuing as a mixture.

The most commonly used type of heat exchanger is recuperative. This group primarily include tubular and plate heat exchanger. From the point of view flow is the most common counter-flow design, which results in better heat distribution than in parallel flow design.

Design with shaped tubes represent different tube axis arranged in the shape of a helix, spiral etc., located in the shell.

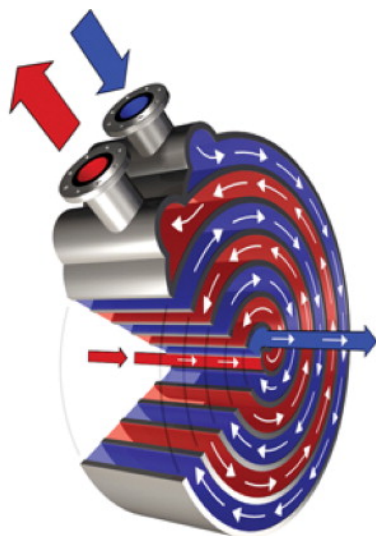

Fig. 3 Spiral tube heat exchanger

Exchangers in design tube in tube are among the simplest device in the above category. It's occurred like dismountable and non-dismountable which are exclusively for pure thermal media.



Fig. 4 Shell & tube heat exchanger

In general the tube exchanger with jacket is the most commonly used heat exchanger, where the main structure consists of a tube bundle placed in the shell of a cylindrical shape. These exchangers are manufactured at many different versions, depending on the configuration of inlet and outlet orifices, pipes, construction attachment of different thermal dilatation of tubes and plastics etc. This type of heat exchanger typically includes partitions that perform two basic functions. Arrestment of tubes resulting in a reduction of bending and vibration and also primarily direct the flow of media that is purposely altered to the cross-flow that increase the intensity of

### 3.1 Tube heat exchanger

In this type of exchanger, heat exchange takes place between the tube and the tubular-space. Tubular space normally consists of pipes or tubes of circular cross section, but we can meet with cross-sections of other shapes such as oval, square etc. To reduce the dimensional parameters of tubular exchangers can use all sorts of ways to increase the area of the pipe from the side of the pipe as well as the tubular space. For this purpose are used, for example ribs.

Tube heat exchangers can be divided according to the construction on:

- With shaped tubes
- With straight pipes
  - Tube in tube
  - Tube in the shell

heat transfer. The system also has the disadvantage that, with the inclusion of partitions create higher pressure drop.

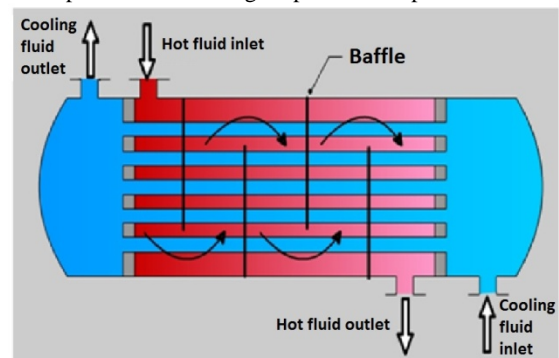

Fig. 5 Tube heat exchanger with baffles

Tube heat exchangers are characterized by good heat resistance and affordable price. However, their disadvantages are small compactness and high weight. The case of the pipes with small diameter, in which is the aqueous medium dirty it's expected gradual decrease of the cross-section pipe up to its complete clogging.



Fig. 6 Real construction of tube heat exchanger with baffles

### 3.2 Plate heat exchanger

Plate heat exchangers are based on a patent that has already been registered in 1878 by German inventor Albrecht Dracke. This principle, when one liquid cooling another liquid and liquids are flowing on both sides of group thin metal plates, became the basis for the construction of the heat exchanger - commercial plate pasteurizer Alfa Laval.

For more than 130 years was plate heat exchangers developed and structurally modified to devices that are used in thousands of different applications in all industries. Plate heat exchanger was previously designed for heating and cooling of the milk, but now

is commonly used for heating and cooling in industrial processes and it is the basis of air-conditioning in buildings or it provides heating of hot water for hundreds of millions of people.

This type of heat exchanger is characterized with a row lying plates which bear shaped reinforcements create turbulence of heat transfer medium and enlarge the heat-conveying surface. The heat transfer medium, as shown in the figure flows between the slabs of small thickness, whereby the heat is transmitted between substances mainly convective. Plate heat exchangers can be sorted into dismantlable and non-dismountable. Non-dismountable exchangers are usually occur in the brazing or welding design, which can also be used in case of the aggressive heat transfer medium. For plate heat exchangers is a clear advantage of their higher performance per unit area, therefore low weight and small size which is for the same performance about 5 times smaller than in tubular heat exchangers. However, the benefits are offset by higher prices and demanding production technology.

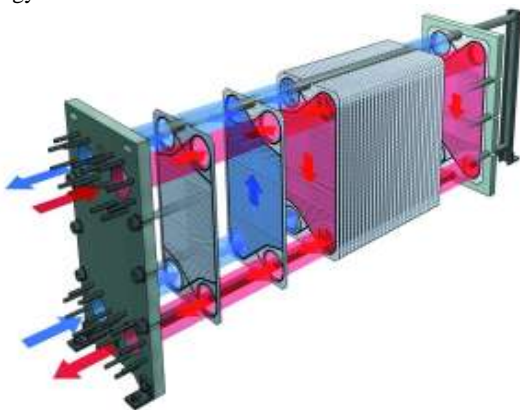

Fig. 7: Plate heat exchanger

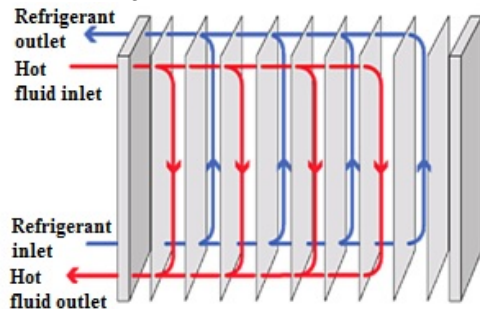

Fig. 8 Fluid flow in plate heat exchanger

#### 4. Draft of exhaust gas heat exchanger

Draft of exhaust gas heat exchanger was realized according to these input parameters

Table 1: Input parameters for draft of heat exchanger

Required power	4,4 kW	Exhaust gas side		Cooling liquid side	
		Flow	82,5 m <sup>3</sup> /h	Flow	0,69 m <sup>3</sup> /h
		Inlet temp.	584 °C	Inlet temp.	89,5 °C
		Outlet temp.	≈115 °C	Outlet temp.	≈95,6 °C

Based on the input values I calculated the parameters of the flue gas heat exchanger which are as follows:

Table 2: Calculated parameters of the exhaust gas heat exchanger

Structural design	
Calculated power	4,8 kW
Number of pipes	48
Length of heat exchanger	1000 mm
Volume of heat exchange area	2,03 m <sup>2</sup>

Based on the calculated parameters I suggested and modelled flue gas heat exchanger.

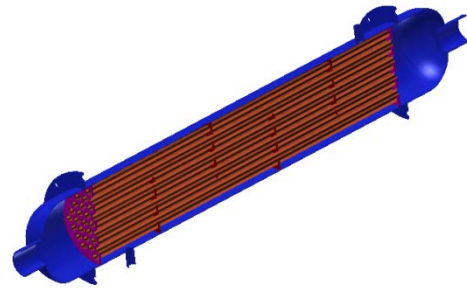

9: 3D model of designed exhaust gas exchanger

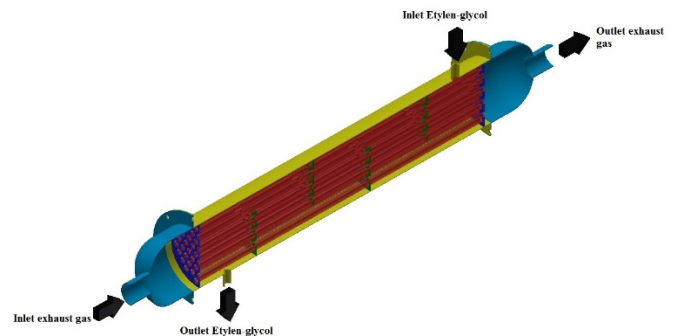

Fig. 10: Stream direction of working substances cross the heat exchanger. Stream direction of working substance cross the heat exchanger was chosen like a counter-flow how you can see in fig 10.

On the proposed exhaust gas heat exchanger was made simulations of flow of exhaust gases and heat transfer in a 3D simulation program COMSOL Multiphysics.

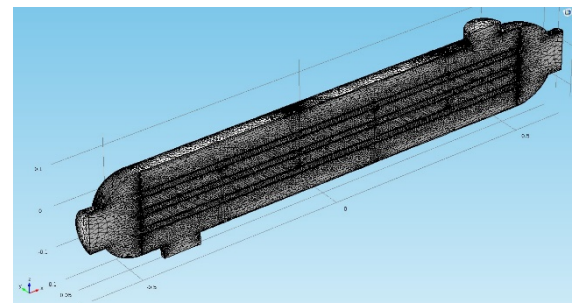

Fig. 11: Layering of the mesh in the model

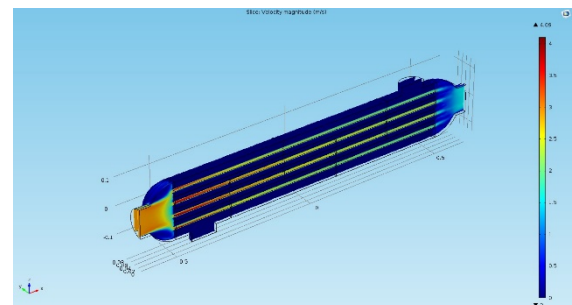

Fig. 12: Simulation of velocity magnitude of exhaust gas heat exchanger in m/s

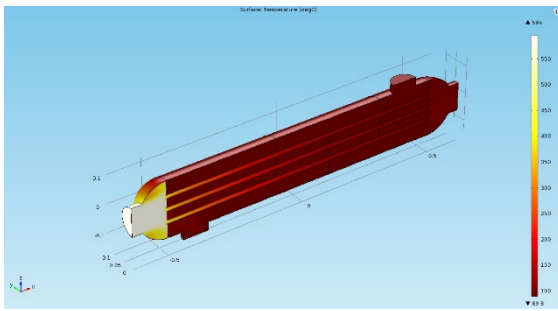

Fig. 13: Temperature of exhaust gas heat exchanger in degC

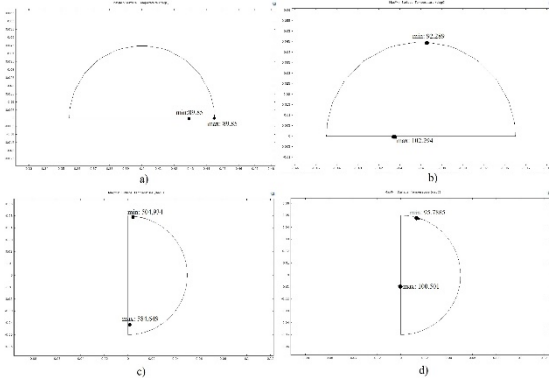

Fig. 14: Comparison of temperatures between inlet and outlet working substances

In Fig 13 we can see Comparison between inlet a) and outlet b) temperature of cooling liquid. Inlet temperature is 363 K (89.85 degC) and mean outlet temperature is 370 K (97 degC). Comparison between inlet temperature c) and outlet temperature d) of exhaust gas. Inlet temperature is 857 K (584 degC) and mean outlet temperature is 373.3 K (98.2 degC). The simulation shows that the draft is correct, because outlet temperatures of working substances are very similar to the required parameters. Cooling liquid side required outlet temperature ≈ 96.5 degC vs outlet temperature from simulation = 97 degC. Exhaust gas side required outlet temperature ≈ 115 degC vs outlet temperature from simulation = 98.2 degC.

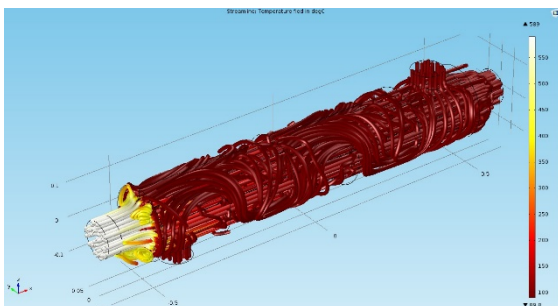

Fig. 15: Streamline in exhaust gas heat exchanger

### 5. Conclusion

The aim of my work was based on the input parameters to calculate and design a 3D model of the exhaust gas heat exchanger and create a simulation of the proposed model in COMSOL Multiphysics. The simulations were performed under conditions of the internal combustion engine warmed up to operating temperature. In the next plan will be made simulation under the condition of a cold combustion engine. After verifying the correctness of the draft by created simulations will be made the real model of exhaust gas heat exchanger. Subsequently will be performed the measurement of heat exchanger connected to the real combustion engine for the purpose of validate the correctness of the draft.

### References:

[1] Holubčík, M.- Hužvár, J.: Jandačka, J.: Combined production of heat and electricity with use of micro cogeneration, IN-TECH 2011 International Conference on Innovative Technologies, year 2011, s. 200-202, ISBN 978-80-904502-6-4

[2] Nemeč, P.: Hužvár, J.: Proposal of heat exchanger in micro-cogeneration unit, configuration with biomass combustion In: Development of materials science in research and education: the nineteenth joint seminar. - [Bratislava: Slovak Society for Industrial Chemistry, 2009]. - ISBN 978-80-89088-81-2. - S. 28-29.

### Acknowledgement:

This contribution is the result of the project implementation: Modern methods of teaching of control and diagnostic systems of engine vehicles, ITMS code 26110230107, supported by the Operational Programme Educational.



The Agency of the Ministry of Education, Science, Research and Sport of the Slovak Republic for the Structural Funds EU

